



## SCHEME OF TEACHING AND EXAMINATION

### B.E Electronics & Communication Engineering / Telecommunication Engineering (Common to Electronics & Communication and Telecommunication Engineering)

#### VII SEMESTER

Sl. No	Subject Code	Title	Teaching Hours /Week		Examination				15EC
			Theory	Practical/Drawing	Duration	I.A. Marks	Theory/Practical Marks	Total Marks	
1	15EC71	Microwave and Antennas	04		03	20	80	100	4
2	15EC72	Digital Image Processing	04		03	20	80	100	4
3	15EC73	Power Electronics	04		03	20	80	100	4
4	15XX74X	Professional Elective-3	03		03	20	80	100	3
5	15EC75X	Professional Elective-4	03		03	20	80	100	3
6	15ECL76	Advanced Communication Lab		1I+2P	03	20	80	100	2
7	15ECL77	VLSI Lab		1I+2P	03	20	80	100	2
8	15ECP78	Project Work Phase-I + Project work Seminar		03		100	-	100	2
<b>TOTAL</b>			<b>18</b>	<b>09</b>	<b>21</b>	<b>240</b>	<b>560</b>	<b>800</b>	<b>24</b>

Professional Elective-3		Professional Elective-4	
15EC741	Multimedia Communication	15EC751	DSP Algorithms and Architecture
15EC742	Biomedical Signal Processing	15EC752	IoT and Wireless Sensor Networks
15EC743	Real Time Systems	15EC753	Pattern Recognition
15EC744	Cryptography	15EC754	Advanced Computer Architecture
15EC745	CAD for VLSI	15EC755	Satellite Communication

**1. Project Phase -I + Project Work Seminar:** Literature Survey, Problem Identification, Objectives and Methodology. Submission of Synopsis and Seminar.

**SCHEME OF TEACHING AND EXAMINATION**  
**B.E.: Electronics & Communication Engineering**

**VIII SEMESTER**

Sl. No	Subject Code	Title	Teaching Hours /Week		Examination				Credits
			Theory	Practical/ Drawing	Duration	I.A. Marks	Theory/ Practical Marks	Total Marks	
1	15EC81	Wireless Cellular and LTE 4G Broadband	4	-	3	20	80	100	4
2	15EC82	Fiber Optics & Networks	4	-	3	20	80	100	4
3	15EC83X	Professional Elective-5	3	-	3	20	80	100	3
4	15EC84	Internship/Professional Practice	Industry Oriented		3	50	50	100	2
5	15ECP85	Project Work	-	6	3	100	100	200	6
6	15ECS86	Seminar	-	4	-	100	-	100	1
<b>TOTAL</b>			<b>11</b>	<b>10</b>	<b>15</b>	<b>310</b>	<b>390</b>	<b>700</b>	<b>20</b>

<b>Professional Elective -5</b>	
15EC831	Micro Electro Mechanical Systems
15EC832	Speech Processing
15EC833	Radar Engineering
15EC834	Machine learning
15EC835	Network and Cyber Security

**1. Internship / Professional Practice:** To be carried between the (6<sup>th</sup> and 7<sup>th</sup> Semester) or (7<sup>th</sup> and 8<sup>th</sup>) Semester Vacation period.



## **B.E E&C SEVENTH SEMESTER SYLLABUS**

### **MICROWAVES AND ANTENNAS**

**B.E., VII Semester, Electronics & Communication Engineering**

[As per Choice Based Credit System (CBCS) scheme]

<b>Course Code</b>	<b>15EC71</b>	<b>IA Marks</b>	<b>20</b>
<b>Number of Lecture Hours/Week</b>	<b>04</b>	<b>Exam Marks</b>	<b>80</b>
<b>Total Number of Lecture Hours</b>	<b>50 (10 Hours / Module)</b>	<b>Exam Hours</b>	<b>03</b>

#### **CREDITS – 04**

**Course objectives:** This course will enable students to:

- Describe the microwave properties and its transmission media
- Describe microwave devices for several applications
- Understand the basics of antenna theory
- Select antennas for specific applications

#### **Module-1**

**Microwave Tubes:** Introduction, Reflex Klystron Oscillator, Mechanism of Oscillations, Modes of Oscillations, Mode Curve (Qualitative Analysis only). (Text 1: 9.1, 9.2.2)

**Microwave Transmission Lines:** Microwave Frequencies, Microwave devices, Microwave Systems, Transmission Line equations and solutions, Reflection Coefficient and Transmission Coefficient, Standing Wave and Standing Wave Ratio, Smith Chart, Single Stub matching. (Text 2: 0.1, 0.2, 0.3, 3.1, 3.2, 3.3, 3.5, 3.6 Except Double stub matching) **L1, L2**

#### **Module-2**

**Microwave Network theory:** Symmetrical Z and Y-Parameters for Reciprocal Networks, S matrix representation of Multi-Port Networks. (Text 1: 6.1, 6.2, 6.3)

**Microwave Passive Devices:** Coaxial Connectors and Adapters, Attenuators, Phase Shifters, Waveguide Tees, Magic tees. (Text 1: 6.4.2, 6.4.14, 6.4.15, 6.4.16) **L1, L2**

#### **Module-3**

**Strip Lines:** Introduction, Micro Strip lines, Parallel Strip lines, Coplanar Strip lines, Shielded Strip Lines. (Text 2: Chapter 11)

**Antenna Basics:** Introduction, Basic Antenna Parameters, Patterns, Beam Area, Radiation Intensity, Beam Efficiency, Directivity and Gain, Antenna Apertures, Effective Height, Bandwidth, Radio Communication Link, Antenna Field Zones & Polarization. (Text 3: 2.1- 2.11, 2.13,2.15) **L1, L2, L3**

#### Module-4

**Point Sources and Arrays:** Introduction, Point Sources, Power Patterns, Power Theorem, Radiation Intensity, Field Patterns, Phase Patterns, Arrays of Two Isotropic Point Sources, Pattern Multiplication, Linear Arrays of n Isotropic Point Sources of equal Amplitude and Spacing. (Text 3: 5.1 – 5.10, 5.13)

**Electric Dipoles:** Introduction, Short Electric Dipole, Fields of a Short Dipole (General and Far Field Analyses), Radiation Resistance of a Short Dipole, Thin Linear Antenna (Field Analyses), Radiation Resistances of  $\lambda/2$  Antenna. (Text 3: 6.1 - 6.6)

**L1, L2, L3, L4**

#### Module-5

**Loop and Horn Antenna:** Introduction, Small loop, Comparison of Far fields of Small Loop and Short Dipole, The Loop Antenna General Case, Far field Patterns of Circular Loop Antenna with Uniform Current, Radiation Resistance of Loops, Directivity of Circular Loop Antennas with Uniform Current, Horn antennas Rectangular Horn Antennas. (Text 3: 7.1-7.8, 7.19, 7.20)

**Antenna Types:** Helical Antenna, Helical Geometry, Practical Design Considerations of Helical Antenna, Yagi-Uda array, Parabola General Properties, Log Periodic Antenna. (Text 3: 8.3, 8.5, 8.8, 9.5, 11.7) **L1, L2, L3**

**Course Outcomes:** At the end of the course, students will be able to:

- Describe the use and advantages of microwave transmission
- Analyze various parameters related to microwave transmission lines and waveguides
- Identify microwave devices for several applications
- Analyze various antenna parameters necessary for building an RF system
- Recommend various antenna configurations according to the applications

#### Text Books:

1. **Microwave Engineering** – Annapurna Das, Sisir K Das TMH Publication, 2<sup>nd</sup>, 2010.
2. **Microwave Devices and circuits**- Liao, Pearson Education.
3. **Antennas and Wave Propagation**, John D. Krauss, Ronald J Marhefka and Ahmad S Khan, 4<sup>th</sup> Special Indian Edition , McGraw- Hill Education Pvt. Ltd., 2010.

#### Reference Books:

1. **Microwave Engineering** – David M Pozar, John Wiley India Pvt. Ltd. 3<sup>rd</sup>Edn, 2008.
2. **Microwave Engineering** – Sushrut Das, Oxford Higher Education, 2<sup>nd</sup>Edn, 2015.
3. **Antennas and Wave Propagation** – Harish and Sachidananda: Oxford University Press, 2007.

## DIGITAL IMAGE PROCESSING

### **B.E., VII Semester, Electronics & Communication Engineering**

[As per Choice Based Credit System (CBCS) scheme]

Subject Code	15EC72	IA Marks	20
Number of Lecture Hours/Week	04	Exam Marks	80
Total Number of Lecture Hours	50 (10 Hours / Module)	Exam Hours	03
CREDITS – 04			
<p><b>Course Objectives:</b> The objectives of this course are to:</p> <ul style="list-style-type: none"> <li>• Understand the fundamentals of digital image processing</li> <li>• Understand the image transform used in digital image processing</li> <li>• Understand the image enhancement techniques used in digital image processing</li> <li>• Understand the image restoration techniques and methods used in digital image processing</li> <li>• Understand the Morphological Operations and Segmentation used in digital image processing</li> </ul>			
<b>Module-1</b>			<b>RBT Level</b>
<p><b>Digital Image Fundamentals:</b> What is Digital Image Processing?, Origins of Digital Image Processing, Examples of fields that use DIP, Fundamental Steps in Digital Image Processing, Components of an Image Processing System, Elements of Visual Perception, Image Sensing and Acquisition, Image Sampling and Quantization, Some Basic Relationships Between Pixels, Linear and Nonlinear Operations. [Text: Chapter 1 and Chapter 2: Sections 2.1 to 2.5, 2.6.2]</p>			L1, L2
<b>Module-2</b>			
<p><b>Spatial Domain:</b> Some Basic Intensity Transformation Functions, Histogram Processing, Fundamentals of Spatial Filtering, Smoothing Spatial Filters, Sharpening Spatial Filters <b>Frequency Domain:</b> Preliminary Concepts, The Discrete Fourier Transform (DFT) of Two Variables, Properties of the 2-D DFT, Filtering in the Frequency Domain, Image Smoothing and Image Sharpening Using Frequency Domain Filters, Selective Filtering. [Text: Chapter 3: Sections 3.2 to 3.6 and Chapter 4: Sections 4.2, 4.5 to 4.10]</p>			L1, L2, L3
<b>Module-3</b>			
<p><b>Restoration:</b> Noise models, Restoration in the Presence of Noise Only using Spatial Filtering and Frequency Domain Filtering, Linear, Position-Invariant Degradations, Estimating the Degradation Function, Inverse Filtering, Minimum Mean Square Error (Wiener) Filtering, Constrained Least Squares Filtering. [Text: Chapter 5: Sections 5.2, to 5.9]</p>			L1, L2, L3
<b>Module-4</b>			

<p><b>Color Image Processing:</b> Color Fundamentals, Color Models, Pseudocolor Image Processing.</p> <p><b>Wavelets:</b> Background, Multiresolution Expansions.</p> <p><b>Morphological Image Processing:</b> Preliminaries, Erosion and Dilation, Opening and Closing, The Hit-or-Miss Transforms, Some Basic Morphological Algorithms.</p> <p>[Text: Chapter 6: Sections 6.1 to 6.3, Chapter 7: Sections 7.1 and 7.2, Chapter 9: Sections 9.1 to 9.5]</p>	L1, L2, L3
<b>Module-5</b>	
<p><b>Segmentation:</b> Point, Line, and Edge Detection, Thresholding, Region-Based Segmentation, Segmentation Using Morphological Watersheds.</p> <p><b>Representation and Description:</b> Representation, Boundary descriptors.</p> <p>[Text: Chapter 10: Sections 10.2, to 10.5 and Chapter 11: Sections 11.1 and 11.2]</p>	L1, L2, L3
<p><b>Course Outcomes:</b> At the end of the course students should be able to:</p> <ul style="list-style-type: none"> <li>• Understand image formation and the role human visual system plays in perception of gray and color image data.</li> <li>• Apply image processing techniques in both the spatial and frequency (Fourier) domains.</li> <li>• Design image analysis techniques in the form of image segmentation and to evaluate the Methodologies for segmentation.</li> <li>• Conduct independent study and analysis of Image Enhancement techniques.</li> </ul> <p><b>Question paper pattern:</b></p> <ul style="list-style-type: none"> <li>• The question paper will have ten questions.</li> <li>• Each full question consists of 16 marks.</li> <li>• There will be 2 full questions (with a maximum of Three sub questions) from each module.</li> <li>• Each full question will have sub questions covering all the topics under a module. The students will have to answer 5 full questions, selecting one full question from each module.</li> </ul>	
<p><b>Text Book:</b></p> <p><b>Digital Image Processing-</b> Rafael C Gonzalez and Richard E. Woods, PHI 3rd Edition 2010.</p> <p><b>Reference Books:</b></p> <ol style="list-style-type: none"> <li>1. <b>Digital Image Processing-</b> S.Jayaraman, S.Esakkirajan, T.Veerakumar, Tata McGraw Hill 2014.</li> <li>2. <b>Fundamentals of Digital Image Processing-</b>A. K. Jain, Pearson 2004.</li> </ol>	

## **POWER ELECTRONICS**

**B.E., VII Semester, Electronics & Communication Engineering**

[As per Choice Based Credit System (CBCS) scheme]

<b>Course Code</b>	<b>15EC73</b>	<b>IA Marks</b>	<b>20</b>
<b>Number of Lecture Hours/Week</b>	<b>04</b>	<b>Exam Marks</b>	<b>80</b>
<b>Total Number of Lecture Hours</b>	<b>50 (10 Hours / Module)</b>	<b>Exam Hours</b>	<b>03</b>

### **CREDITS – 04**

**Course Objectives:** This course will enable students to:

- Understand the construction and working of various power devices.
- Study and analysis of thyristor circuits with different triggering conditions.
- Learn the applications of power devices in controlled rectifiers, converters and inverters.
- Study of power electronics circuits under various load conditions.

#### **Module-1**

Introduction - Applications of Power Electronics, Power Semiconductor Devices, Control Characteristics of Power Devices, types of Power Electronic Circuits, Peripheral Effects. Power Transistors: Power BJTs: Steady state characteristics. Power MOSFETs: device operation, switching characteristics, IGBTs: device operation, output and transfer characteristics, di/dt and dv/dt limitations. (Text 1)

**L1, L2**

#### **Module-2**

Thyristors - Introduction, Principle of Operation of SCR, Static Anode-Cathode Characteristics of SCR, Two transistor model of SCR, Gate Characteristics of SCR, Turn-ON Methods, Turn-OFF Mechanism, Turn-OFF Methods: Natural and Forced Commutation – Class A and Class B types, Gate Trigger Circuit: Resistance Firing Circuit, Resistance capacitance firing circuit, UJT Firing Circuit. (Text 2)

**L1, L2, L3**

#### **Module-3**

Controlled Rectifiers - Introduction, Principle of Phase-Controlled Converter Operation, Single-Phase Full Converter with RL Load, Single-Phase Dual Converters, Single-Phase Semi Converter with RL load.

AC Voltage Controllers - Introduction, Principles of ON-OFF Control, Principle of Phase Control, Single phase controllers with resistive and inductive loads. (Text 1)

**L1, L2, L3**

#### **Module-4**

DC-DC Converters - Introduction, principle of step-down operation and its analysis with RL load, principle of step-up operation, Step-up converter with a resistive load, Performance parameters, Converter classification, Switching mode regulators: Buck regulator, Boost regulator, Buck-Boost Regulators, Chopper circuit design. (Text 1)

**L1, L2**

#### **Module-5**

Pulse Width Modulated Inverters- Introduction, principle of operation, performance parameters, Single phase bridge inverters, voltage control of single phase inverters,

current source inverters, Variable DC-link inverter, Boost inverter, Inverter circuit design.

Static Switches: Introduction, Single phase AC switches, DC Switches, Solid state relays, Microelectronic relays. (Text 1) **L1, L2**



**Course Outcomes:** At the end of the course students should be able to:

- Describe the characteristics of different power devices and identify the various applications associated with it.
- Illustrate the working of power circuit as DC-DC converter.
- Illustrate the operation of inverter circuit and static switches.
- Determine the output response of a thyristor circuit with various triggering options.
- Determine the response of controlled rectifier with resistive and inductive loads.

**Evaluation of Internal Assessment Marks:**

It is suggested that at least 4 experiments of Power Electronics to be conducted by the students. This activity can be considered for the evaluation of 05 marks out of 20 Internal Assessment (IA) Marks, reserved for the other activities.

**Text Books:**

1. Mohammad H Rashid, Power Electronics, Circuits, Devices and Applications, 3<sup>rd</sup>/4<sup>th</sup> Edition, Pearson Education Inc, 2014, ISBN: 978-93-325-1844-5.
2. M.D Singh and K B Khanchandani, Power Electronics, 2nd Edition, Tata Mc-Graw Hill, 2009, ISBN: 0070583897

**Reference Books:**

1. L. Umanand, Power Electronics, Essentials and Applications, John Wiley India Pvt. Ltd, 2009.
2. Dr. P. S. Bimbhra, "Power Electronics", Khanna Publishers, Delhi, 2012.
3. P.C. Sen, "Modern Power Electronics", S Chand & Co New Delhi, 2005.
4. Earl Gose, Richard Johnsonbaugh, Steve Jost, Pattern Recognition and Image Analysis, ePub eBook.

**MULTIMEDIA COMMUNICATION**

**B.E., VII Semester, Electronics & Communication Engineering/  
Telecommunication Engineering**

[As per Choice Based credit System (CBCS) Scheme

Subject Code	15EC741	IA Marks	20
Number of Lecture Hours/Week	03	Exam Marks	80
Total Number of Lecture Hours	40 (08 Hours / Module)	Exam Hours	03

CREDITS – 03

**Course objectives:** This course will enable students to:

- Gain fundamental knowledge in understanding the basics of different multimedia networks and applications.
- Understand digitization principle techniques required to analyze different media types.
- Analyze compression techniques required to compress text and image and gain knowledge of DMS.
- Analyze compression techniques required to compress audio and video.
- Gain fundamental knowledge about multimedia communication across different networks.

<b>Module-1</b>	<b>RBT Level</b>
<b>Multimedia Communications:</b> Introduction, Multimedia information representation, multimedia networks, multimedia applications, Application and networking terminology. (Chap 1 of Text 1)	L1,L2
<b>Module-2</b>	
<b>Information Representation:</b> Introduction, Digitization principles, Text, Images, Audio and Video (Chap 2 of Text 1)	L1, L2
<b>Module-3</b>	
<b>Text and image compression:</b> Introduction, Compression principles, text compression, image Compression. (Chap 3 of Text 1)	L1,L2,L3
<b>Distributed multimedia systems:</b> Introduction, main Features of a DMS, Resource management of DMS, Networking, Multimedia operating systems (Chap. 4 - Sections 4.1 to 4.5 of Text 2).	
<b>Module-4</b>	
<b>Audio and video compression:</b> Introduction, Audio compression, video compression, video compression principles, video compression. (Chap. 4 of Text 1).	L1,L2,L3
<b>Module-5</b>	
<b>Multimedia Communication Across Networks:</b> Packet audio/video in the L2 network environment, Video transport across generic networks, Multimedia Transport across ATM Networks (Chap. 6 - Sections 6.1, 6.2, 6.3 of Text 2).	L1,
<b>Course Outcomes:</b> After studying this course, students will be able to:	
<ul style="list-style-type: none"> <li>• Understand basics of different multimedia networks and applications.</li> <li>• Understand different compression techniques to compress audio and video.</li> <li>• Describe multimedia Communication across Networks.</li> <li>• Analyse different media types to represent them in digital form.</li> <li>• Compress different types of text and images using different compression techniques and analyse DMS.</li> </ul>	
<b>Question paper pattern:</b>	
<ul style="list-style-type: none"> <li>• The question paper will have ten questions.</li> <li>• Each full question consists of 16 marks.</li> <li>• There will be 2 full questions (with a maximum of Three sub questions) from each module.</li> <li>• Each full question will have sub questions covering all the topics under a module.</li> <li>• The students will have to answer 5 full questions, selecting one full question from each module.</li> </ul>	
<b>Text Books:</b>	
<ol style="list-style-type: none"> <li>1. Fred Halsall, “Multimedia Communications”, Pearson education, 2001 ISBN - 9788131709948.</li> <li>2. K. R. Rao, Zoran S. Bojkovic, Dragorad A. Milovanovic, “Multimedia Communication Systems”, Pearson education, 2004. ISBN -9788120321458</li> </ol>	

**Reference Book:**

Raifsteinmetz, Klara Nahrstedt, "Multimedia: Computing, Communications and Applications", Pearson education, 2002. ISBN -9788177584417

**BIOMEDICAL SIGNAL PROCESSING****B.E., VII Semester, Electronics & Communication Engineering/  
Telecommunication Engineering**

[As per Choice Based Credit System (CBCS) scheme]

Subject Code	15EC742	IA Marks	20
Number of Lecture Hours/Week	03	Exam Marks	80
Total Number of Lecture Hours	40 (8 Hours / Module)	Exam Hours	03
CREDITS – 03			
<b>Course Objectives:</b> The objectives of this course are to:			
<ul style="list-style-type: none"> <li>• Describe the origin, properties and suitable models of important biological signals such as ECG and EEG.</li> <li>• Introduce students to basic signal processing techniques in analysing biological signals.</li> <li>• Develop the students mathematical and computational skills relevant to the field of biomedical signal processing.</li> <li>• Develop a thorough understanding on basics of ECG signal compression algorithms.</li> <li>• Increase the student's awareness of the complexity of various biological phenomena and cultivate an understanding of the promises, challenges of the biomedical engineering.</li> </ul>			
<b>Module-1</b>			<b>RBT Level</b>
<b>Introduction to Biomedical Signals:</b> The nature of Biomedical Signals, Examples of Biomedical Signals, Objectives and difficulties in Biomedical analysis. <b>Electrocardiography:</b> Basic electrocardiography, ECG lead systems, ECG signal characteristics. <b>Signal Conversion :</b> Simple signal conversion systems, Conversion requirements for biomedical signals, Signal conversion circuits (Text-1)			L1, L2
<b>Module-2</b>			
<b>Signal Averaging:</b> Basics of signal averaging, signal averaging as a digital filter, a typical averager, software for signal averaging, limitations of signal averaging. <b>Adaptive Noise Cancelling:</b> Principal noise canceller model, 60-Hz adaptive cancelling using a sine wave model, other applications of adaptive filtering (Text-1)			L1, L2, L3
<b>Module-3</b>			
<b>Data Compression Techniques:</b> Turning point algorithm, AZTEC algorithm, Fan algorithm, Huffman coding, data reduction algorithms The Fourier transform, Correlation, Convolution, Power spectrum estimation, Frequency domain analysis of the ECG (Text-1)			L1, L2, L3

<b>Module-4</b>	
<p><b>Cardiological signal processing:</b>  Basic Electrocardiography, ECG data acquisition, ECG lead system, ECG signal characteristics (parameters and their estimation), Analog filters, ECG amplifier, and QRS detector, Power spectrum of the ECG, Bandpass filtering techniques, Differentiation techniques, Template matching techniques, A QRS detection algorithm, Realtime ECG processing algorithm, ECG interpretation, ST segment analyzer, Portable arrhythmia monitor. (Text -2)</p>	L1, L2, L3
<b>Module-5</b>	
<p><b>Neurological signal processing:</b> The brain and its potentials, The electrophysiological origin of brain waves, The EEG signal and its characteristics (EEG rhythms, waves, and transients), Correlation.</p> <p><b>Analysis of EEG channels:</b> Detection of EEG rhythms, Template matching for EEG, spike and wave detection (Text-2).</p>	L1, L2, L3
<p><b>Course outcomes:</b> At the end of the course, students will be able to:</p> <ul style="list-style-type: none"> <li>• Possess the basic mathematical, scientific and computational skills necessary to analyse ECG and EEG signals.</li> <li>• Apply classical and modern filtering and compression techniques for ECG and EEG signals</li> <li>• Develop a thorough understanding on basics of ECG and EEG feature extraction.</li> </ul>	
<p><b>Question paper pattern:</b></p> <ul style="list-style-type: none"> <li>• The question paper will have ten questions.</li> <li>• Each full question consists of 16 marks.</li> <li>• There will be 2 full questions (with a maximum of Three sub questions) from each module.</li> <li>• Each full question will have sub questions covering all the topics under a module. The students will have to answer 5 full questions, selecting one full question from each module.</li> </ul>	
<p><b>Text Books:</b></p> <ol style="list-style-type: none"> <li>1. <b>Biomedical Digital Signal Processing-</b> Willis J. Tompkins, PHI 2001.</li> <li>2. <b>Biomedical Signal Processing Principles and Techniques-</b> D C Reddy, McGraw-Hill publications 2005</li> </ol>	
<p><b>Reference Book:</b></p> <p><b>Biomedical Signal Analysis-</b>Rangaraj M. Rangayyan, John Wiley &amp; Sons 2002</p>	



## REAL TIME SYSTEMS

**B.E., VII Semester, Electronics & Communication Engineering**  
**/Telecommunication Engineering** [As per Choice Based Credit System (CBCS)  
 scheme]

Subject Code	15EC743	IA Marks	20
Number of Lecture Hours/Week	03	Exam marks	80
Total Number of Lecture Hours	40 (08 Hours per Module)	Exam Hours	03
Credits – 03			
<p><b>Course Objectives:</b> This Course will enable students to:</p> <ul style="list-style-type: none"> <li>• Discuss the historical background of Real-time systems and its classifications.</li> <li>• Describe the concepts of computer control and hardware components for Real-Time Application.</li> <li>• Discuss the languages to develop software for Real-Time Applications.</li> <li>• Explain the concepts of operating system and RTS development methodologies.</li> </ul>			
<b>Modules</b>			<b>RBT Level</b>
<b>Module-1</b>			
<p><b>Introduction to Real-Time Systems:</b> Historical background, Elements of a Computer Control System, RTS- Definition, Classification of Real-time Systems, Time Constraints, Classification of Programs.</p> <p><b>Concepts of Computer Control:</b> Introduction, Sequence Control, Loop Control, Supervisory Control, Centralized Computer Control, Hierarchical Systems. (Text Book: 1.1 to 1.6 and 2.1 to 2.6)</p>			<b>L1, L2</b>
<b>Module-2</b>			
<p><b>Computer Hardware Requirements for Real-Time Applications:</b> Introduction, General Purpose Computer, Single Chip Microcomputers and Microcontrollers, Specialized Processors, Process-Related Interfaces, Data Transfer Techniques, Communications, Standard Interface.(Text Book: 3.1 to 3.8)</p>			<b>L1, L2</b>
<b>Module-3</b>			
<p><b>Languages for Real-Time Applications:</b> Introduction, Syntax Layout and Readability, Declaration and Initialization of Variables and Constants, Modularity and Variables, Compilation of Modular Programs, Data types, Control Structures, Exception Handling, Low-level facilities, Co-routines, Interrupts and Device Handling, Concurrency, Real-Time Support, Overview of Real-Time Languages. (Text Book: 5.1 to 5.14)</p>			<b>L1, L2, L3</b>
<b>Module-4</b>			
<p><b>Operating Systems:</b> Introduction, Real-Time Multi-Tasking OS, Scheduling Strategies, Priority Structures, Task Management, Scheduler and Real-Time Clock Interrupt Handler, Memory Management, Code Sharing, Resource Control, Task Co-Operation and Communication, Mutual Exclusion.(Text Book: 6.1 to 6.11)</p>			<b>L1, L2</b>

<b>Module-5</b>	
<p><b>Design of RTS – General Introduction:</b> Introduction, Specification Document, Preliminary Design, Single-Program Approach, Foreground/Background System.</p> <p><b>RTS Development Methodologies:</b> Introduction, Yourdon Methodology, Ward and Mellor Method, Hatley and Pirbhai Method. (Text Book: 7.1 to 7.5 and 8.1, 8.2, 8.4,8.5)</p>	<b>L1, L2, L3</b>
<p><b>Course Outcomes:</b> At the end of the course, students should be able to:</p> <ul style="list-style-type: none"> <li>• Understand the fundamentals of Real time systems and its classifications.</li> <li>• Understand the concepts of computer control, operating system and the suitable computer hardware requirements for real-time applications.</li> <li>• Develop the software languages to meet Real time applications.</li> <li>• Apply suitable methodologies to design and develop Real-Time Systems.</li> </ul>	
<p><b>Question Paper Pattern:</b></p> <ul style="list-style-type: none"> <li>• The question paper will have ten questions.</li> <li>• Each full Question consisting of 16 marks</li> <li>• There will be 2 full questions (with a maximum of Three sub questions) from each module.</li> <li>• Each full question will have sub questions covering all the topics under a module.</li> <li>• The students will have to answer 5 full questions, selecting one full question from each module.</li> </ul>	
<p><b>Text Book:</b> Real-Time Computer Control, by Stuart Bennet, 2nd Edn. Pearson Education. 2008.</p>	
<p><b>Reference Books:</b></p> <ol style="list-style-type: none"> <li>1. C.M. Krishna, Kang G. Shin, “Real –Time Systems”, McGraw –Hill International Editions, 1997.</li> <li>2. Real-Time Systems Design and Analysis, Phillip. A. Laplante, second edition, PHI, 2005.</li> <li>3. Embedded Systems, Raj Kamal, Tata McGraw Hill, India, third edition, 2005.</li> </ol>	

## Cryptography

### **B.E., VII Semester, Electronics & Communication Engineering**

[As per Choice Based Credit System (CBCS) scheme]

Subject Code	15EC744	IA Marks	20
Number of Lecture Hours/Week	03	Exam Marks	80
Total Number of Lecture Hours	40 (08 Hours / Module)	Exam Hours	03
CREDITS – 03			
<b>Course Objectives:</b> This Course will enable students to:			
<ul style="list-style-type: none"> <li>• Enable students to understand the basics of symmetric key and public key cryptography.</li> <li>• Equip students with some basic mathematical concepts and pseudorandom number generators required for cryptography.</li> <li>• Enable students to authenticate and protect the encrypted data.</li> <li>• Enrich knowledge about Email, IP and Web security.</li> </ul>			
<b>Modules</b>			
<b>Module-1</b>			<b>RBT Level</b>
<b>Basic Concepts of Number Theory and Finite Fields:</b> Divisibility and the divisibility algorithm, Euclidean algorithm, Modular arithmetic, Groups, Rings and Fields, Finite fields of the form GF(p), Polynomial arithmetic, Finite fields of the form GF(2 <sup>n</sup> )(Text 1: Chapter 3)			L1, L2
<b>Module-2</b>			
<b>Classical Encryption Techniques:</b> Symmetric cipher model, Substitution techniques, Transposition techniques, Steganography (Text 1: Chapter 1) <b>SYMMETRIC CIPHERS:</b> Traditional Block Cipher structure, Data Encryption Standard (DES) (Text 1: Chapter 2: Section 1, 2)			L1, L2
<b>Module-3</b>			
<b>SYMMETRIC CIPHERS:</b> The AES Cipher(Text1: Chapter 4: Section 2,3,4)  <b>Pseudo-Random-Sequence Generators and Stream Ciphers:</b> Linear Congruential Generators, Linear Feedback Shift Registers, Design and analysis of stream ciphers, Stream ciphers using LFSRs (Text 2: Chapter 16: Section 1, 2, 3, 4)			L1, L2, L3
<b>Module-4</b>			
<b>More number theory:</b> Prime Numbers, Fermat's and Euler's theorem, Primality testing, Chinese Remainder theorem, discrete logarithm. (Text 1: Chapter 7) <b>Principles of Public-Key Cryptosystems:</b> The RSA algorithm, Diffie - Hellman Key Exchange, Elliptic Curve Arithmetic, Elliptic Curve Cryptography (Text 1: Chapter 8, Chapter 9: Section 1, 3, 4)			L1, L2, L3
<b>Module-5</b>			
<b>One-Way Hash Functions:</b> Background, Snefru, N-Hash, MD4, MD5, Secure Hash Algorithm [SHA], One way hash functions using symmetric block algorithms, Using public key algorithms, Choosing a one-way hash functions, Message Authentication Codes. Digital Signature Algorithm, Discrete Logarithm Signature Scheme (Text 2: Chapter 18: Section 18.1 to			L1, L2, L3



~~18.5, 18.7, 18.11 to 18.14 and Chapter 20: Section 20.1, 20.4)~~

**Course Outcomes:** After studying this course, students will be able to:

- Use basic cryptographic algorithms to encrypt the data.
- Generate some pseudorandom numbers required for cryptographic applications.
- Provide authentication and protection for encrypted data.

**Question paper pattern:**

- The question paper will have 10 full questions carrying equal marks.
- Each full question consists of 16 marks with a maximum of Three sub questions.
- There will be 2 full questions from each module covering all the topics of the module
- ~~The students will have to answer 5 full questions, selecting one full question from each module.~~

**Text Books:**

1. William Stallings , “Cryptography and Network Security Principles and Practice”, Pearson Education Inc., 6<sup>th</sup> Edition, 2014, ISBN: 978-93-325-1877-3
2. Bruce Schneier, “Applied Cryptography Protocols, Algorithms, and Source code in C”, Wiley Publications, 2<sup>nd</sup> Edition, ISBN: 9971-51-348-X

**Reference Books:**

1. Cryptography and Network Security, Behrouz A. Forouzan, TMH, 2007.
2. Cryptography and Network Security, Atul Kahate, TMH, 2003.

### CAD for VLSI

#### **B.E., VII Semester, Electronics & Communication Engineering**

[As per Choice Based Credit System (CBCS) scheme]

Subject Code	15EC745	IA Marks	20
Number of Lecture Hours/Week	03	Exam marks	80
Total Number of Lecture Hours	40 (8 Hours per Module)	Exam Hours	03
CREDITS – 03			
<b>Course Objectives:</b> This course will enable students to: <ul style="list-style-type: none"><li>• Understand various stages of Physical design of VLSI circuits</li><li>• Know about mapping a design problem to a realizable algorithm</li><li>• Become aware of graph theoretic, heuristic and genetic algorithms</li><li>• Compare performance of different algorithms</li></ul>			
<b>Modules</b>			<b>RBT Level</b>
<b>Module 1</b>			
<b>Data Structures and Basic Algorithms:</b> Basic terminology, Complexity issues and NP-Hardness. Examples - Exponential, heuristic, approximation and special cases. Basic Algorithms. Graph Algorithms for Search, spanning tree, shortest path, min-cut and max-cut, Steiner tree. Computational Geometry Algorithms: Line sweep and extended line sweep methods.			L1, L2
<b>Module 2</b>			
<b>Basic Data Structures.</b> Atomic operations for layout editors, Linked list of blocks, Bin-based method, Neighbor pointers, corner-stitching, Multi-layer operations, Limitations of existing data structures. Layout specification languages.  <b>Graph algorithms for physical design:</b> Classes of graphs in physical design, Relationship between graph classes, Graph problems in physical design, Algorithms for Interval graphs, permutation graphs and circle graphs.			L1, L2
<b>Module 3</b>			

<p><b>Partitioning:</b> Problem formulation, Design style specific partitioning problems, Classification of Partitioning Algorithms. Group migration algorithms: Kernighan-Lin algorithm, Fiduccia-Mattheyses Algorithm, Simulated Annealing, Simulated Evolution.</p> <p><b>Floor Planning:</b> Problem formulation, Constraint based floor planning, Rectangular dualization, Simulated evolution algorithms.</p>	L1, L2,L3
<b>Module 4</b>	
<p><b>Pin Assignment:</b> Problem formulation. Classification of pin assignment problems, General pin assignment problem.</p> <p><b>Placement:</b> Problem formulation, Classification of placement algorithms. Simulation based placement: Simulated annealing, simulated evolution, force directed placement. Partitioning based algorithms: Breur's Algorithm, Terminal propagation algorithm, Other algorithms for placement.</p>	L1,L2,L3
<b>Module 5</b>	
<p><b>Global Routing:</b> Problem formulation, Classification of Global routing algorithms, Maze routing algorithms: Lee's algorithm, Soukup's algorithm and Hadlock's Algorithm, Line probe algorithms.</p> <p><b>Detailed Routing:</b> Problem formulation, Routing considerations, models, channel routing and switch box routing problems. General river routing problem, Single row routing problem.</p> <p>Two-layer channel routing algorithms: Basic Left Edge Algorithm, Dogleg router, Symbolic router-YACR2.</p>	L1,L2,L3
<p><b>Course Outcomes:</b> After studying this course, students will be able to:</p> <ul style="list-style-type: none"> <li>• Appreciate the problems related to physical design of VLSI</li> <li>• Use generalized graph theoretic approach to VLSI problems</li> <li>• Design Simulated Annealing and Evolutionary algorithms</li> <li>• Know various approaches to write generalized algorithms</li> </ul>	
<p><b>Question paper pattern:</b></p> <ul style="list-style-type: none"> <li>• The question paper will have 10 full questions carrying equal marks.</li> <li>• Each full question consists of 16 marks with a maximum of Three sub questions.</li> <li>• There will be 2 full questions from each module covering all the topics of the module</li> <li>• The students will have to answer 5 full questions, selecting one full question from each module.</li> </ul>	

**Text Book:**

Algorithms for VLSI Physical Design Automation, 3<sup>rd</sup> Ed, Naveed Sherwani, 1999 Kluwer Academic Publishers, Reprint 2009 Springer (India) Private Ltd. ISBN 978-81-8128-317-7.

## DSP Algorithms and Architecture

**B.E., VII Semester, Electronics & Communication  
Engineering / Telecommunication Engineering**  
[As per Choice Based Credit System (CBCS) scheme]

Subject Code	15EC751	IA Marks	20
Number of Lecture Hours/Week	03	Exam Marks	80
Total Number of Lecture Hours	40 (8 Hours / Module)	Exam Hours	03
CREDITS – 03			
<p><b>Course Objectives:</b> This course will enable students to:</p> <ul style="list-style-type: none"> <li>• Figure out the knowledge and concepts of digital signal processing techniques.</li> <li>• Understand the computational building blocks of DSP processors and its speed issues.</li> <li>• Understand the various addressing modes, peripherals, interrupts and pipelining structure of TMS320C54xx processor.</li> <li>• Learn how to interface the external devices to TMS320C54xx processor in various modes.</li> <li>• Understand basic DSP algorithms with their implementation.</li> </ul>			
<b>Module-1</b>			<b>RBT Level</b>
<p><b>Introduction to Digital Signal Processing:</b> Introduction, A Digital Signal – Processing System, The Sampling Process, Discrete Time Sequences, Discrete Fourier Transform (DFT) and Fast Fourier Transform (FFT), Linear Time-Invariant Systems, Digital Filters, Decimation and Interpolation.</p> <p><b>Computational Accuracy in DSP Implementations:</b> Number Formats for Signals and Coefficients in DSP Systems, Dynamic Range and Precision, Sources of Error in DSP Implementation.</p>			L1, L2
<b>Module-2</b>			
<p><b>Architectures for Programmable Digital Signal – Processing Devices:</b> Introduction, Basic Architectural Features, DSP Computational Building Blocks, Bus Architecture and Memory, Data Addressing Capabilities, Address Generation Unit, Programmability and Program Execution, Speed Issues, Features for External Interfacing.</p>			L1, L2, L3
<b>Module-3</b>			
<p><b>Programmable Digital Signal Processors:</b> Introduction, Commercial Digital Signal-processing Devices, Data Addressing Modes of TMS320C54XX, Memory Space of TMS320C54xx Processors, Program Control. Detail Study of TMS320C54X &amp; 54xx Instructions and Programming, On – Chip Peripherals, Interrupts of TMS320C54XX Processors, Pipeline Operation of TMS320C54xx Processor.</p>			L1, L2, L3
<b>Module-4</b>			

<p><b>Implementation of Basic DSP Algorithms:</b> Introduction, The Q – notation, FIR Filters, IIR Filters, Interpolation and Decimation Filters (one example in each case).</p> <p><b>Implementation of FFT Algorithms:</b> Introduction, An FFT Algorithm for DFT Computation, Overflow and Scaling, Bit – Reversed Index. Generation &amp; Implementation on the TMS320C54xx.</p>	L1, L2, L3
<b>Module-5</b>	
<p><b>Interfacing Memory and Parallel I/O Peripherals to Programmable DSP Devices:</b> Introduction, Memory Space Organization, External Bus Interfacing Signals. Memory Interface, Parallel I/O Interface, Programmed I/O, Interrupts and I/O Direct Memory Access (DMA).</p> <p><b>Interfacing and Applications of DSP Processors:</b> Introduction, Synchronous Serial Interface, A CODEC Interface Circuit, DSP Based Bio-telemetry Receiver, A Speech Processing System, An Image Processing System.</p>	L1, L2, L3
<p><b>Course Outcomes:</b> At the end of this course, students would be able to</p> <ul style="list-style-type: none"> <li>• Comprehend the knowledge and concepts of digital signal processing techniques.</li> <li>• Apply the knowledge of DSP computational building blocks to achieve speed in DSP architecture or processor.</li> <li>• Apply knowledge of various types of addressing modes, interrupts, peripherals and pipelining structure of TMS320C54xx processor.</li> <li>• Develop basic DSP algorithms using DSP processors.</li> <li>• Discuss about synchronous serial interface and multichannel buffered serial port (McBSP) of DSP device.</li> <li>• Demonstrate the programming of CODEC interfacing.</li> </ul>	
<p><b>Question paper pattern:</b></p> <ul style="list-style-type: none"> <li>• The question paper will have 10 full questions carrying equal marks.</li> <li>• Each full question consists of 16 marks with a maximum of Three sub questions.</li> <li>• There will be 2 full questions from each module covering all the topics of the module</li> <li>• The students will have to answer 5 full questions, selecting one full question from each module.</li> </ul>	
<p><b>Text Book:</b> “Digital Signal Processing”, Avatar Singh and S. Srinivasan, Thomson Learning, 2004.</p>	
<p><b>Reference Books:</b></p> <ol style="list-style-type: none"> <li>1. “Digital Signal Processing: A practical approach”, Ifeachor E. C., Jervis B. W Pearson-Education, PHI, 2002.</li> <li>2. “Digital Signal Processors”, B Venkataramani and M Bhaskar, TMH, 2nd, 2010</li> <li>3. “Architectures for Digital Signal Processing”, Peter Pirsch John Wiley, 2008</li> </ol>	

## **IoT & WIRELESS SENSOR NETWORKS**

### **B.E., VII Semester, Electronics & Communication Engineering /Telecommunication Engineering**

[As per Choice Based Credit System (CBCS) scheme]

Subject Code	15EC752	IA Marks	20
Number of Lecture Hours/Week	03	Exam Marks	80
Total Number of Lecture Hours	40 (8 Hours / Module)	Exam Hours	03
CREDITS – 03			
<p><b>Course Objectives:</b> This course will enable students to:</p> <ul style="list-style-type: none"> <li>• Understand various sources of IoT &amp; M2M communication protocols.</li> <li>• Describe Cloud computing and design principles of IoT.</li> <li>• Become aware of MQTT clients, MQTT server and its programming.</li> <li>• Understand the architecture and design principles of WSNs.</li> <li>• Enrich the knowledge about MAC and routing protocols in WSNs.</li> </ul>			
<b>Module-1</b>			<b>RBT Level</b>
<p><b>Overview of Internet of Things:</b> IoT Conceptual Framework, IoT Architectural View, Technology Behind IoT, Sources of IoT, M2M communication, Examples of IoT. Modified OSI Model for the IoT/M2M Systems, data enrichment, data consolidation and device management at IoT/M2M Gateway, web communication protocols used by connected IoT/M2M devices, Message communication protocols (CoAP-SMS, CoAP-MQ, MQTT, XMPP) for IoT/M2M devices.</p>			L1, L2
<b>Module-2</b>			
<p><b>Architecture and Design Principles for IoT:</b> Internet connectivity, Internet-based communication, IPv4, IPv6, 6LoWPAN protocol, IP Addressing in the IoT, Application layer protocols: HTTP, HTTPS, FTP, TELNET and ports.</p> <p><b>Data Collection, Storage and Computing using a Cloud Platform:</b> Introduction, Cloud computing paradigm for data collection, storage and computing, Cloud service models, IoT Cloud- based data collection, storage and computing services using Nimbits.</p>			L1, L2
<b>Module-3</b>			

<p><b>Prototyping and Designing Software for IoT Applications:</b> Introduction, Prototyping Embedded device software, Programming Embedded Device Arduino Platform using IDE, Reading data from sensors and devices, Devices, Gateways, Internet and Web/Cloud services software development.</p> <p>Programming MQTT clients and MQTT server. Introduction to IoT privacy and security. Vulnerabilities, security requirements and threat analysis, IoT Security Tomography and layered attacker model.</p>	L1, L2, L3
<b>Module-4</b>	
<p><b>Overview of Wireless Sensor Networks:</b> Challenges for Wireless Sensor Networks, Enabling Technologies for Wireless Sensor Networks.</p> <p><b>Architectures:</b> Single-Node Architecture - Hardware Components, Energy Consumption of Sensor Nodes, Operating Systems and Execution Environments, Network Architecture-Sensor Network Scenarios, Optimization Goals and Figures of Merit, Design principles for WSNs, Service interfaces of WSNs Gateway Concepts.</p>	L1, L2, L3
<b>Module-5</b>	
<p><b>Communication Protocols:</b> Physical Layer and Transceiver Design Considerations, MAC Protocols for Wireless Sensor Networks, Low Duty Cycle Protocols And Wakeup Concepts - S-MAC , The Mediation Device Protocol, Wakeup Radio Concepts, Contention based protocols(CSMA,PAMAS), Schedule based protocols (LEACH, SMACS, TRAMA) Address and Name Management in WSNs, Assignment of MAC Addresses, Routing Protocols- Energy-Efficient Routing, Geographic Routing, Hierarchical networks by clustering.</p>	L1, L2, L3
<p><b>Course Outcomes:</b> At the end of the course, students will be able to:</p> <ul style="list-style-type: none"> <li>• Describe the OSI Model for the IoT/M2M Systems.</li> <li>• Understand the architecture and design principles for IoT.</li> <li>• Learn the programming for IoT Applications.</li> <li>• Identify the communication protocols which best suits the WSNs.</li> </ul>	
<p><b>Question paper pattern:</b></p> <ul style="list-style-type: none"> <li>• The question paper will have ten questions.</li> <li>• Each full Question consisting of 16 marks.</li> <li>• There will be 2 full questions (with a maximum of Three sub questions) from each module.</li> <li>• Each full question will have sub questions covering all the topics under a module.</li> <li>• The students will have to answer 5 full questions, selecting one full question from each module.</li> </ul>	



**Text Books:**

1. Raj Kamal, "Internet of Things-Architecture and design principles", McGraw Hill Education.
2. Holger Karl & Andreas Willig, "Protocols And Architectures for Wireless Sensor Networks" , John Wiley, 2005.
3. Feng Zhao & Leonidas J. Guibas, "Wireless Sensor Networks- An Information Processing Approach", Elsevier, 2007.

**Reference Books:**

1. Kazem Sohraby, Daniel Minoli, & Taieb Znati, "Wireless Sensor Networks- Technology, Protocols, And Applications", John Wiley, 2007.
2. Anna Hac, "Wireless Sensor Network Designs", John Wiley, 2003.

## PATTERN RECOGNITION

### **B.E., VII Semester, Electronics & Communication Engineering/ Telecommunication Engineering**

[As per Choice Based Credit System (CBCS) scheme]

Subject Code	15EC753	IA Marks	20
Number of Lecture Hours/Week	03	Exam Marks	80
Total Number of Lecture Hours	40 (8 Hours / Module)	Exam Hours	03
CREDITS – 03			
<p><b>Course Objectives:</b> The objectives of this course are to:</p> <ul style="list-style-type: none"> <li>• Introduce mathematical tools needed for Pattern Recognition</li> <li>• Impart knowledge about the fundamentals of Pattern Recognition.</li> <li>• Provide knowledge of recognition, decision making and statistical learning problems</li> <li>• Introduce parametric and non-parametric techniques, supervised learning and clustering concepts of pattern recognition</li> </ul>			
<b>Modules</b>			
<b>Module-1</b>			<b>RBT Level</b>
<p><b>Introduction:</b> Importance of pattern recognition, Features, Feature Vectors, and Classifiers, Supervised, Unsupervised, and Semi-supervised learning, Introduction to Bayes Decision Theory, Discriminant Functions and Decision Surfaces, Gaussian PDF and Bayesian Classification for Normal Distributions.</p>			L1, L2
<b>Module-2</b>			
<p><b>Data Transformation and Dimensionality Reduction:</b> Introduction, Basis Vectors, The Karhunen Loeve (KL) Transformation, Singular Value Decomposition, Independent Component Analysis (Introduction only). Nonlinear Dimensionality Reduction, Kernel PCA.</p>			L1, L2
<b>Module-3</b>			
<p><b>Estimation of Unknown Probability Density Functions:</b> Maximum Likelihood Parameter Estimation, Maximum a Posteriori Probability estimation, Bayesian Interference, Maximum Entropy Estimation, Mixture Models, Naive-Bayes Classifier, The Nearest Neighbor Rule.</p>			L1, L2, L3
<b>Module-4</b>			
<p><b>Linear Classifiers:</b> Introduction, Linear Discriminant Functions and Decision Hyperplanes, The Perceptron Algorithm, Mean Square Error Estimate, Stochastic Approximation of LMS Algorithm, Sum of Error Estimate.</p>			L1,2, L3
<b>Module-5</b>			
<p><b>Nonlinear Classifiers:</b> The XOR Problem, The two Layer Perceptron, Three Layer Perceptron, Back propagation Algorithm, Basic Concepts of Clustering, Introduction to Clustering , Proximity Measures.</p>			L1,2,L3

**Course outcomes:** At the end of the course, students will be able to:

- Identify areas where Pattern Recognition and Machine Learning can offer a solution.
- Describe the strength and limitations of some techniques used in computational Machine Learning for classification, regression and density estimation problems
- Describe genetic algorithms, validation methods and sampling techniques
- Describe and model data to solve problems in regression and classification
- Implement learning algorithms for supervised tasks

---

**Question paper pattern:**

The question paper will have ten questions.

- Each full question consists of 16 marks.
- There will be 2 full questions (with a maximum of Three sub questions) from each module.
- Each full question will have sub questions covering all the topics under a module. The students will have to answer 5 full questions, selecting one full question from each module.

---

**Text Book:**

**Pattern Recognition:** Sergios Theodoridis, Konstantinos Koutroumbas, Elsevier India Pvt. Ltd (Paper Back), 4th edition.

---

**Reference Books:**

1. **The Elements of Statistical Learning:** Trevor Hastie, Springer-Verlag New York, LLC (Paper Back), 2009.
2. **Pattern Classification:** Richard O. Duda, Peter E. Hart, David G. Stork. John Wiley & Sons, 2012.
3. **Pattern Recognition and Image Analysis Earl Gose:** Richard Johnsonbaugh, Steve Jost, ePub eBook.

## **ADVANCED COMPUTER ARCHITECTURE**

### **B.E., VII Semester, Electronics & Communication Engineering / Telecommunication Engineering**

[As per Choice Based Credit System (CBCS) scheme]

Subject Code	15EC754	IA Marks	20
Number of Lecture Hours/Week	03	Exam Marks	80
Total Number of Lecture Hours	40 (8 Hours / Module)	Exam Hours	03
CREDITS – 03			
<ul style="list-style-type: none"> <li>• Understand the various parallel computer models and conditions of parallelism</li> <li>• Explain the control flow, dataflow and demand driven machines</li> <li>• Study CISC, RISC, superscalar, VLIW and multiprocessor architectures</li> <li>• Understand the concept of pipelining and memory hierarchy design</li> <li>• Explain cache coherence protocols.</li> </ul>			
<b>Module-1</b>			<b>RBT Level</b>
<p><b>Parallel Computer Models:</b> The state of computing, Classification of parallel computers, Multiprocessors and multicomputer, Multivectors and SIMD computers.</p> <p><b>Program and Network Properties:</b> Conditions of parallelism, Data and resource Dependences, Hardware and software parallelism, Program partitioning and scheduling, Grain Size and latency.</p>			L1, L2
<b>Module-2</b>			
<p><b>Program flow mechanisms:</b> Control flow versus data flow, Data flow Architecture, Demand driven mechanisms, Comparisons of flow mechanisms.</p> <p><b>Principles of Scalable Performance:</b> Performance Metrics and Measures, Parallel Processing Applications, Speedup Performance Laws, Scalability Analysis and Approaches.</p>			L1, L2,L3
<b>Module-3</b>			
<p><b>Speedup Performance Laws:</b> Amdhal’s law, Gustafson’s law, Memory bounded speed up model, Scalability Analysis and Approaches.</p> <p><b>Advanced Processors:</b> Advanced processor technology, Instruction-set Architectures, CISC Scalar Processors, RISC Scalar Processors, Superscalar Processors, VLIW Architectures.</p>			L1,L2,L3
<b>Module-4</b>			
<p><b>Pipelining:</b> Linear pipeline processor, nonlinear pipeline processor, Instruction pipeline Design, Mechanisms for instruction pipelining, Dynamic instruction scheduling, Branch Handling techniques, branch prediction, Arithmetic Pipeline Design.</p> <p><b>Memory Hierarchy Design:</b> Cache basics &amp; cache performance, reducing miss rate and miss penalty, multilevel cache hierarchies, main memory organizations, design of memory hierarchies.</p>			L1,L2,L3

---

<b>Module-5</b>	
<b>Multiprocessor Architectures:</b> Symmetric shared memory architectures, distributed shared memory architectures, models of memory consistency, cache coherence protocols (MSI, MESI, MOESI), scalable cache coherence, overview of directory based approaches, design challenges of directory protocols, memory based directory protocols, cache based directory protocols.	L1, L2, L3
<p><b>Course Outcomes:</b> At the end of the course, the students will be able to:</p> <ul style="list-style-type: none"> <li>• Explain parallel computer models and conditions of parallelism</li> <li>• Differentiate control flow, dataflow, demand driven mechanisms</li> <li>• Explain the principle of scalable performance</li> <li>• Discuss advanced processors architectures like CISC, RISC, superscalar and VLIW</li> <li>• Understand the basics of instruction pipelining and memory technologies</li> <li>• Explain the issues in multiprocessor architectures</li> </ul>	
<p><b>Question paper pattern:</b> The question paper will have ten questions.</p> <ul style="list-style-type: none"> <li>• Each full question consists of 16 marks.</li> <li>• There will be 2 full questions (with a maximum of Three sub questions) from each module.</li> <li>• Each full question will have sub questions covering all the topics under a module. The students will have to answer 5 full questions, selecting one full question from each module.</li> </ul>	
<p><b>Text Book:</b> Kai Hwang, “Advanced computer architecture”; TMH.</p>	
<p><b>Reference Books:</b></p> <ol style="list-style-type: none"> <li>1. Kai Hwang and Zu, “Scalable Parallel Computers Architecture”; MGH.</li> <li>2. M.J Flynn, “Computer Architecture, Pipelined and Parallel Processor Design”; Narosa Publishing.</li> <li>3. D.A.Patterson, J.L.Hennessy, “Computer Architecture :A quantitative approach”; Morgan Kauffmann Feb, 2002.</li> </ol>	

## **SATELLITE COMMUNICATION**

### **B.E., VII Semester, Electronics & Communication Engineering**

[As per Choice Based Credit System (CBCS)]

Subject Code	15EC755	IA Marks	20
Number of Lecture Hours/Week	03	Exam Marks	80
Total Number of Lecture Hours	40 (8 Hours / Module)	Exam Hours	03
CREDITS – 03			
<p><b>Course Objectives:</b> This course will enable students to</p> <ul style="list-style-type: none"> <li>• Understand the basic principle of satellite orbits and trajectories.</li> <li>• Study of electronic systems associated with a satellite and the earth station.</li> <li>• Understand the various technologies associated with the satellite communication.</li> <li>• Focus on a communication satellite and the national satellite system.</li> <li>• Study of satellite applications focusing various domains services such as remote sensing, weather forecasting and navigation.</li> </ul>			
<b>Module-1</b>			<b>RBT Level</b>
<p><b>Satellite Orbits and Trajectories:</b> Definition, Basic Principles, Orbital parameters, Injection velocity and satellite trajectory, Types of Satellite orbits, Orbital perturbations, Satellite stabilization, Orbital effects on satellite's performance, Eclipses, Look angles: Azimuth angle, Elevation angle.</p>			L1, L2
<b>Module-2</b>			
<p><b>Satellite subsystem:</b> Power supply subsystem, Attitude and Orbit control, Tracking, Telemetry and command subsystem, Payload.</p> <p><b>Earth Station:</b> Types of earth station, Architecture, Design considerations, Testing, Earth station Hardware, Satellite tracking.</p>			L1, L2
<b>Module-3</b>			
<p><b>Multiple Access Techniques:</b> Introduction, FDMA (No derivation), SCPC Systems, MCPC Systems, TDMA, CDMA, SDMA.</p> <p><b>Satellite Link Design Fundamentals:</b> Transmission Equation, Satellite Link Parameters, Propagation considerations.</p>			L1, L2, L3
<b>Module-4</b>			
<p><b>Communication Satellites:</b> Introduction, Related Applications, Frequency Bands, Payloads, Satellite Vs. Terrestrial Networks, Satellite Telephony, Satellite Television, Satellite radio, Regional satellite Systems, National Satellite Systems.</p>			L1, L2
<b>Module-5</b>			





<p><b>Remote Sensing Satellites:</b> Classification of remote sensing systems, orbits, Payloads, Types of images: Image Classification, Interpretation, Applications.</p> <p><b>Weather Forecasting Satellites:</b> Fundamentals, Images, Orbits, Payloads, Applications.</p> <p><b>Navigation Satellites:</b> Development of Satellite Navigation Systems, GPS system, Applications.</p>	<p>L1, L2, L3</p>
<p><b>Course Outcomes:</b> At the end of the course, the students will be able to:</p> <ul style="list-style-type: none"> <li>• Describe the satellite orbits and its trajectories with the definitions of parameters associated with it.</li> <li>• Describe the electronic hardware systems associated with the satellite subsystem and earth station.</li> <li>• Describe the various applications of satellite with the focus on national satellite system.</li> <li>• Compute the satellite link parameters under various propagation conditions with the illustration of multiple access techniques.</li> </ul>	
<p><b>Question Paper pattern:</b></p> <ul style="list-style-type: none"> <li>• The Question paper will have ten questions.</li> <li>• Each full Question consisting of 16 marks</li> <li>• There will be 2 full Questions (with a maximum of Three sub questions) from each module.</li> <li>• Each full question will have sub questions covering all the topics under a module.</li> <li>• The Students will have to answer 5 full Questions, selecting one full Question</li> <li>• from each module.</li> </ul>	
<p><b>Text Book:</b></p> <p>Anil K. Maini, Varsha Agrawal, Satellite Communications, Wiley India Pvt. Ltd., 2015, ISBN: 978-81-265-2071-8.</p>	
<p><b>Reference Books :</b></p> <ol style="list-style-type: none"> <li>1. Dennis Roddy, Satellite Communications, 4<sup>th</sup> Edition, McGraw- Hill International edition, 2006</li> <li>2. Timothy Pratt, Charles Bostian, Jeremy Allnut, Satellite Communications, 2<sup>nd</sup> Edition, Wiley India Pvt. Ltd , 2017, ISBN: 978-81-265-0833-4</li> </ol>	

## **ADVANCED COMMUNICATION LAB**

### **B.E., VII Semester, Electronics & Communication Engineering**

[As per Choice Based Credit System (CBCS) scheme]

Subject Code	15ECL76	IA Marks	20
Number of Lecture Hours/Week	01Hr Tutorial (Instructions) + 02 Hours Laboratory = 03	Exam Marks	80
RBT Levels	L1, L2, L3	Exam Hours	03

CREDITS – 02

**Course objectives:** This course will enable students to:

- Design and demonstrate the digital modulation techniques
- Demonstrate and measure the wave propagation in microstrip antennas
- Characteristics of microstrip devices and measurement of its parameters.
- Model an optical communication system and study its characteristics.
- Simulate the digital communication concepts and compute and display various parameters along with plots/figures.

#### **Laboratory Experiments**

**PART-A: Following Experiments No. 1 to 4 has to be performed using discrete components.**

1. Time Division Multiplexing and Demultiplexing of two bandlimited signals.
2. ASK generation and detection
3. FSK generation and detection
4. PSK generation and detection
5. Measurement of frequency, guide wavelength, power, VSWR and attenuation in microwave test bench.
6. Measurement of directivity and gain of microstrip dipole and Yagi antennas.
7. Determination of
  - a. Coupling and isolation characteristics of microstrip directional coupler.
  - b. Resonance characteristics of microstrip ring resonator and computation of dielectric constant of the substrate.
  - c. Power division and isolation of microstrip power divider.
8. Measurement of propagation loss, bending loss and numerical aperture of an optical fiber.

**PART-B: Simulation Experiments using SCILAB/MATLAB/Simulink or LabView**

1. Simulate NRZ, RZ, half-sinusoid and raised cosine pulses and generate eye diagram for binary polar signaling.
2. Simulate the Pulse code modulation and demodulation system and display the waveforms.
3. Simulate the QPSK transmitter and receiver. Plot the signals and its constellation diagram.
4. Test the performance of a binary differential phase shift keying system by simulating the non-coherent detection of binary DPSK.

**Course outcomes:** On the completion of this laboratory course, the students will be able to:

- Determine the characteristics and response of microwave devices and optical waveguide.
  - Determine the characteristics of microstrip antennas and devices and compute the parameters associated with it.
  - Simulate the digital modulation schemes with the display of waveforms and computation of performance parameters.
  - Design and test the digital modulation circuits/systems and display the waveforms.
- 
- All laboratory experiments are to be considered for practical examination.
  - For examination one question from **PART-A** and one question from **PART-B** or only one question from **PART-B** experiments based on the complexity, to be set.
  - Students are allowed to pick one experiment from the lot.
  - Strictly follow the instructions as printed on the cover page of answer script for breakup of marks.
  - Change of experiment is allowed only once and Marks allotted to the procedure part to be made zero.

## VLSI LAB

### **B.E., VII Semester, Electronics & Communication Engineering**

[As per Choice Based Credit System (CBCS) scheme]

Subject Code	15ECL77	IA Marks	20
Number of Lecture Hours/Week	01Hr Tutorial (Instructions) + 02 Hours Laboratory = 03	Exam Marks	80
RBT Levels	L1, L2, L3	Exam Hours	03

CREDITS – 02

**Course objectives:** This course will enable students to:

- Explore the CAD tool and understand the flow of the Full Custom IC design cycle.
- Learn DRC, LVS and Parasitic Extraction of the various designs.
- Design and simulate the various basic CMOS analog circuits and use them in higher circuits like data converters using design abstraction concepts.
- Design and simulate the various basic CMOS digital circuits and use them in higher circuits like adders and shift registers using design abstraction concepts.

**Experiments can be conducted using any of the following or equivalent design tools: Cadence/Synopsis/Mentor Graphics/Microwind**

#### **Laboratory Experiments**

#### **PART - A ASIC-DIGITAL DESIGN**

1. Write Verilog Code for the following circuits and their Test Bench for verification, observe the waveform and synthesize the code with technological library with given constraints\*. Do the initial timing verification with gate level simulation.
  - i. An inverter
  - ii. A Buffer
  - iii. Transmission Gate
  - iv. Basic/universal gates
  - v. Flip flop -RS, D, JK, MS, T
  - vi. Serial & Parallel adder
  - vii. 4-bit counter [Synchronous and Asynchronous counter]
  - viii. Successive approximation register [SAR]

**PART - B**  
**ANALOG DESIGN**

1. Design an Inverter with given specifications\*\*, completing the design flow mentioned below:
  - a. Draw the schematic and verify the following
    - i) DC Analysis
    - ii) Transient Analysis
  - b. Draw the Layout and verify the DRC, ERC
  - c. Check for LVS
  - d. Extract RC and back annotate the same and verify the Design
  - e. Verify & Optimize for Time, Power and Area to the given constraint\*
2. Design the (i) Common source and Common Drain amplifier and (ii) A Single Stage differential amplifier, with given specifications\*\*, completing the design flow mentioned below:
  - a. Draw the schematic and verify the following
    - i) DC Analysis
    - ii) AC Analysis
    - iii) Transient Analysis
  - b. Draw the Layout and verify the DRC, ERC
  - c. Check for LVS
  - d. Extract RC and back annotate the same and verify the Design.
3. Design an op-amp with given specification\*\* using given differential amplifier Common source and Common Drain amplifier in library\*\*\* and completing the design flow mentioned below:
  - a. Draw the schematic and verify the following
    - i) DC Analysis
    - ii). AC Analysis
    - iii) Transient Analysis
  - b. Draw the Layout and verify the DRC, ERC
  - c. Check for LVS
  - d. Extract RC and back annotate the same and verify the Design.
4. Design a 4 bit R-2R based DAC for the given specification and completing the design flow mentioned using given op-amp in the library\*\*\*.
  - a. Draw the schematic and verify the following
    - i) DC Analysis
    - ii) AC Analysis
    - iii) Transient Analysis
  - b. Draw the Layout and verify the DRC, ERC

5. For the SAR based ADC mentioned in the figure below draw the mixed signal schematic and verify the functionality by completing ASIC Design FLOW.  
[Specifications to GDS-II]

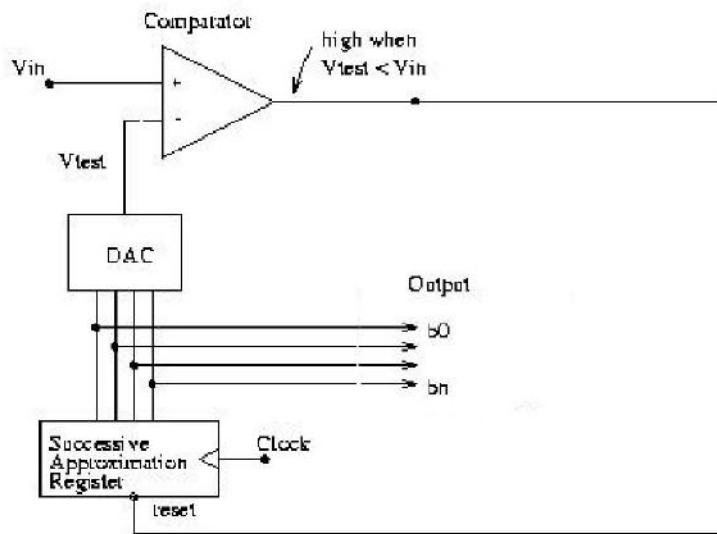

- \* An appropriate constraint should be given.
- \*\* Appropriate specification should be given.
- \*\*\* Applicable Library should be added & information should be given to the Designer.

**Course outcomes:** On the completion of this laboratory course, the students will be able to:

- Write test bench to simulate various digital circuits.
- Interpret concepts of DC Analysis, AC Analysis and Transient Analysis in analog circuits.
- Design and simulate basic CMOS circuits like inverter, common source amplifier and differential amplifiers.
- Use basic amplifiers and further design higher level circuits like operational amplifier and analog/digital converters to meet desired parameters.
- Use transistors to design gates and further using gates realize shift registers and adders to meet desired parameters.

**Conduct of Practical Examination:**

- All laboratory experiments are to be included for practical examination.
- For examination, one question from **PART-A** and one question from **PART-B** to be set.
- Students are allowed to pick one experiment from the lot.
- Change of experiment is allowed only once and Marks allotted to the procedure part to be made zero.

**B.E E&C EIGHTH SEMESTER SYLLABUS**  
**Wireless Cellular and LTE 4G Broadband**

**B.E., VIII Semester, Electronics & Communication Engineering/  
Telecommunication Engineering**

[As per Choice Based Credit System (CBCS) scheme]

Subject Code	15EC81	IA Marks	20
Number of Lecture	04	Exam Marks	80
Total Number	50 (10 Hours / Module)	Exam Hours	03
CREDITS – 04			
<p><b>Course Objectives:</b> This course will enable students to:</p> <ul style="list-style-type: none"> <li>• Understand the basics of LTE standardization phases and specifications.</li> <li>• Explain the system architecture of LTE and E-UTRAN, the layer of LTE, based on the use of OFDMA and SC-FDMA principles.</li> <li>• Analyze the role of LTE radio interface protocols to set up, reconfigure and release the Radio Bearer, for transferring the EPS bearer.</li> <li>• Analyze the main factors affecting LTE performance including mobile speed and transmission bandwidth.</li> </ul>			
<b>Module – 1</b>			<b>RBT Level</b>
<p><b>Key Enablers for LTE features:</b> OFDM, Single carrier FDMA, Single carrier FDE, Channel Dependent Multiuser Resource Scheduling, Multi antenna Techniques, IP based Flat network Architecture, LTE Network Architecture. (Sec 1.4- 1.5 of Text).</p> <p><b>Wireless Fundamentals:</b> Cellular concept, Broadband wireless channel (BWC), Fading in BWC, Modeling BWC – Empirical and Statistical models, Mitigation of Narrow band and Broadband Fading (Sec 2.2 – 2.7of Text).</p>			L1, L2
<b>Module – 2</b>			
<p><b>Multicarrier Modulation:</b> OFDM basics, OFDM in LTE, Timing and Frequency Synchronization, PAR, SC-FDE (Sec 3.2 – 3.6 of Text).</p> <p><b>OFDMA and SC-FDMA:</b>OFDM with FDMA,TDMA,CDMA, OFDMA, SC-FDMA, OFDMA and SC-FDMA in LTE (Sec 4.1 – 4.3, 4.5 of Text).</p> <p><b>Multiple Antenna Transmission and Reception:</b> Spatial Diversity overview, Receive Diversity, Transmit Diversity, Interference cancellation and signal enhancement, Spatial Multiplexing, Choice between Diversity, Interference suppression and Spatial Multiplexing (Sec 5.1 – 5.6 of Text).</p>			L1, L2
<b>Module – 3</b>			
<p><b>Overview and Channel Structure of LTE:</b> Introduction to LTE, Channel Structure of LTE, Downlink OFDMA Radio Resource, Uplink</p>			L1, L2

SC-FDMA Radio Resource(Sec 6.1 – 6.4 of Text).	
<b>Downlink Transport Channel Processing:</b> Overview, Downlink shared channels, Downlink Control Channels, Broadcast channels, Multicast channels, Downlink physical channels, H-ARQ on Downlink(Sec 7.1 – 7.7 of Text).	
<b>Module – 4</b>	
<b>Uplink Channel Transport Processing:</b> Overview, Uplink shared channels, Uplink Control Information, Uplink Reference signals, Random Access Channels, H-ARQ on uplink (Sec 8.1 – 8.6 of Text).	L1, L2
<b>Physical Layer Procedures:</b> Hybrid – ARQ procedures, Channel Quality Indicator CQI feedback, Precoder for closed loop MIMO Operations, Uplink channel sounding, Buffer status Reporting in uplink, Scheduling and Resource Allocation, Cell Search, Random Access Procedures, Power Control in uplink(Sec 9.1- 9.6, 9.8, 9.9, 9.10 Text).	
<b>Module – 5</b>	
<b>Radio Resource Management and Mobility Management:</b> PDCP overview, MAC/RLC overview, RRC overview, Mobility Management, Inter-cell Interference Coordination(Sec 10.1 – 10.5 of Text).	L1, L2
<b>Course Outcomes:</b> At the end of the course, students will be able to:	
<ul style="list-style-type: none"> <li>• Understand the system architecture and the functional standard specified in LTE 4G.</li> <li>• Analyze the role of LTE radio interface protocols and EPS Data convergence protocols to set up, reconfigure and release data and voice from users.</li> <li>• Demonstrate the UTRAN and EPS handling processes from set up to release including mobility management for a variety of data call scenarios.</li> <li>• Test and Evaluate the Performance of resource management and packet data processing and transport algorithms.</li> </ul>	
<b>Question Paper pattern:</b>	
<ul style="list-style-type: none"> <li>• The Question paper will have ten questions.</li> <li>• Each full Question consisting of 16 marks</li> <li>• There will be 2 full Questions (with a maximum of Three sub questions) from each module.</li> <li>• Each full question will have sub questions covering all the topics under a module.</li> <li>• The Students will have to answer 5 full Questions, selecting one full Question from each module.</li> </ul>	
<b>Text Book:</b>	
Arunabha Ghosh, Jan Zhang, Jefferey Andrews, Riaz Mohammed, 'Fundamentals of LTE', Prentice Hall, Communications Engg. and Emerging Technologies.	



**Reference Books:**

1. LTE for UMTS Evolution to LTE-Advanced' Harri Holma and Antti Toskala, Second Edition - 2011, John Wiley & Sons, Ltd. Print ISBN: 9780470660003.
2. 'EVOLVED PACKET SYSTEM (EPS) ; THE LTE AND SAE EVOLUTION OF 3G UMTS' by Pierre Lescuyer and Thierry Lucidarme, 2008, John Wiley & Sons, Ltd. Print ISBN:978-0-470-05976-0.
3. 'LTE – The UMTS Long Term Evolution ; From Theory to Practice' by Stefania Sesia, Issam Toufik, and Matthew Baker, 2009 John Wiley & Sons Ltd, ISBN 978-0-470-69716-0.

## **FIBER OPTICS and NETWORKS**

**B.E., VIII Semester, Electronics & Communication Engineering**  
[As per Choice Based Credit System (CBCS)]

Subject Code	15EC82	IA Marks	20
Number of Lecture Hours/Week	4	Exam Marks	80
Total Number of Lecture Hours	50(10 Hours / Module)	Exam Hours	03
CREDITS – 04			
<p><b>Course Objectives:</b> This course will enable students to:</p> <ul style="list-style-type: none"> <li>• Learn the basic principle of optical fiber communication with different modes of light propagation.</li> <li>• Understand the transmission characteristics and losses in optical fiber.</li> <li>• Study of optical components and its applications in optical communication networks.</li> <li>• Learn the network standards in optical fiber and understand the network architectures along with its functionalities.</li> </ul>			
<b>Module -1</b>			<b>RBT Level</b>
<p><b>Optical fiber Communications:</b> Historical development, The general system, Advantages of optical fiber communication, Optical fiber waveguides: Ray theory transmission, Modes in planar guide, Phase and group velocity, Cylindrical fiber: Modes, Step index fibers, Graded index fibers, Single mode fibers, Cutoff wavelength, Mode field diameter, effective refractive index. Fiber Materials, Photonic crystal fibers. (Text 2)</p>			L1, L2
<b>Module -2</b>			
<p><b>Transmission characteristics of optical fiber:</b> Attenuation, Material absorption losses, Linear scattering losses, Nonlinear scattering losses, Fiber bend loss, Dispersion, Chromatic dispersion, Intermodal dispersion: Multimode step index fiber.</p> <p><b>Optical Fiber Connectors:</b> Fiber alignment and joint loss, Fiber splices, Fiber connectors, Fiber couplers. (Text 2)</p>			L1, L2
<b>Module -3</b>			
<p><b>Optical sources:</b> Energy Bands, Direct and Indirect Bandgaps, Light Emitting diodes: LED Structures, Light Source Materials, Quantum Efficiency and LED Power, Modulation. Laser Diodes: Modes and Threshold conditions, Rate equation, External Quantum Efficiency, Resonant frequencies, Laser Diode structures and Radiation Patterns: Single mode lasers.</p> <p><b>Photodetectors:</b> Physical principles of Photodiodes, Photodetector noise, Detector response time.</p> <p><b>Optical Receiver:</b> Optical Receiver Operation: Error sources,</p>			L1, L2

Front End Amplifiers, Receiver sensitivity, Quantum Limit. (Text 1)	
<b>Module -4</b>	
<b>WDM Concepts and Components:</b> Overview of WDM: Operational Principles of WDM, WDM standards, Mach-Zehnder Interferometer Multiplexers, Isolators and Circulators, Fiber grating filters, Dielectric Thin-Film Filters, Diffraction Gratings, Active Optical Components, Tunable light sources,  <b>Optical amplifiers:</b> Basic application and Types, Semiconductor optical amplifiers, Erbium Doped Fiber Amplifiers, Raman Amplifiers, Wideband Optical Amplifiers. (Text 1)	L1, L2
<b>Module -5</b>	
<b>Optical Networks:</b> Optical network evolution and concepts: Optical networking terminology, Optical network node and switching elements, Wavelength division multiplexed networks, Public telecommunication network overview. Optical network transmission modes, layers and protocols: Synchronous networks, Asynchronous transfer mode, OSI reference model, Optical transport network, Internet protocol, Wavelength routing networks: Routing and wavelength assignment, Optical switching networks: Optical circuit switched networks, packet switched networks, Multiprotocol Label Switching, Optical burst switching networks, Optical network deployment: Long-haul networks, Metropolitan area networks, Access networks, Local area networks. (Text 2)	L1, L2
<p><b>Course Outcomes:</b> At the end of the course, students will be able to:</p> <ol style="list-style-type: none"> <li>1. Classification and working of optical fiber with different modes of signal propagation.</li> <li>2. Describe the transmission characteristics and losses in optical fiber communication.</li> <li>3. Describe the construction and working principle of optical connectors, multiplexers and amplifiers.</li> <li>4. Describe the constructional features and the characteristics of optical sources and detectors.</li> <li>5. Illustrate the networking aspects of optical fiber and describe various standards associated with it.</li> </ol>	
<p><b>Question Paper pattern:</b></p> <ul style="list-style-type: none"> <li>• The Question paper will have ten questions.</li> <li>• Each full Question consisting of 16 marks</li> <li>• There will be 2 full Questions (with a maximum of Three sub questions) from each module.</li> <li>• Each full question will have sub questions covering all the topics under a module.</li> <li>• The Students will have to answer 5 full Questions, selecting one full Question from each module.</li> </ul>	
<p><b>Text Books:</b></p> <ol style="list-style-type: none"> <li>1. Gerd Keiser , Optical Fiber Communication, 5<sup>th</sup> Edition, McGraw Hill</li> </ol>	

Education(India) Private Limited, 2015. ISBN:1-25-900687-5.  
2. John M Senior, Optical Fiber Communications, Principles and Practice,  
3<sup>rd</sup> Edition, Pearson Education, 2010, ISBN:978-81-317-3266-3

**Reference Book:**

Joseph C Palais, Fiber Optic Communication , Pearson Education,  
2005, ISBN:0130085103

## Micro Electro Mechanical Systems

**B.E., VIII Semester, Electronics & Communication Engineering/  
Telecommunication Engineering** [As per Choice Based Credit System  
(CBCS) scheme]

Subject Code	15EC831	IA Marks	20
Number of Lecture Hours/Week	03	Exam marks	80
Total Number of Lecture Hours	40 (8 Hours per Module)	Exam Hours	03
CREDITS – 03			
<p><b>Course Objectives:</b> This course will enable students to:</p> <ul style="list-style-type: none"> <li>• Understand overview of microsystems, their fabrication and application areas.</li> <li>• Working principles of several MEMS devices.</li> <li>• Develop mathematical and analytical models of MEMS devices.</li> <li>• Know methods to fabricate MEMS devices.</li> <li>• Various application areas where MEMS devices can be used.</li> </ul>			
<b>Module 1</b>			<b>RBT Level</b>
<p><b>Overview of MEMS and Microsystems:</b> MEMS and Microsystem, Typical MEMS and Microsystems Products, Evolution of Microfabrication, Microsystems and Microelectronics, Multidisciplinary Nature of Microsystems, Miniaturization. Applications and Markets.</p>			L1, L2
<b>Module 2</b>			
<p><b>Working Principles of Microsystems:</b> Introduction, Microsensors, Microactuation, MEMS with Microactuators, Microaccelerometers, Microfluidics.</p> <p><b>Engineering Science for Microsystems Design and Fabrication:</b> Introduction, Molecular Theory of Matter and Inter-molecular Forces, Plasma Physics, Electrochemistry.</p>			L1, L2
<b>Module 3</b>			
<p><b>Engineering Mechanics for Microsystems Design:</b> Introduction, Static Bending of Thin Plates, Mechanical Vibration, Thermomechanics, Fracture Mechanics, Thin Film Mechanics, Overview on Finite Element Stress Analysis.</p>			L1,L2,L3
<b>Module 4</b>			

<b>Scaling Laws in Miniaturization:</b> Introduction, Scaling in Geometry, Scaling in Rigid-Body Dynamics, Scaling in Electrostatic Forces, Scaling in Fluid Mechanics, Scaling in Heat Transfer.	L1,L2,L3
<b>Module 5</b>	
<b>Overview of Micromanufacturing:</b> Introduction, Bulk Micromanufacturing, Surface Micromachining, The LIGA Process, Summary on Micromanufacturing.	L1,L2
<p><b>Course Outcomes:</b> After studying this course, students will be able to:</p> <ul style="list-style-type: none"> <li>• Appreciate the technologies related to Micro Electro Mechanical Systems.</li> <li>• Understand design and fabrication processes involved with MEMS devices.</li> <li>• Analyse the MEMS devices and develop suitable mathematical models</li> <li>• Know various application areas for MEMS device</li> </ul>	
<p><b>Question paper pattern:</b></p> <ul style="list-style-type: none"> <li>• The question paper will have 10 full questions carrying equal marks.</li> <li>• Each full question consists of 16 marks with a maximum of Three sub questions.</li> <li>• There will be 2 full questions from each module covering all the topics of the module</li> <li>• The students will have to answer 5 full questions, selecting one full question from each module.</li> </ul>	
<p><b>Text Book:</b>          Tai-Ran Hsu, MEMS and Micro systems: Design, Manufacture and Nanoscale Engineering, 2<sup>nd</sup> Ed, Wiley.</p>	
<p><b>Reference Books:</b></p> <ol style="list-style-type: none"> <li>1. Hans H. Gatzert, Volker Saile, JurgLeuthold, Micro and Nano Fabrication: Tools and Processes, Springer, 2015.</li> <li>2. Dilip Kumar Bhattacharya, Brajesh Kumar Kaushik, Microelectromechanical Systems (MEMS), Cenage Learning.</li> </ol>	

## **SPEECH PROCESSING**

### **B.E., VIII Semester, Electronics & Communication Engineering/ Telecommunication Engineering**

[As per Choice Based Credit System (CBCS) scheme]

Subject Code	15EC832	IA Marks	20
Number of Lecture Hours/Week	03	Exam Marks	80
Total Number of Lecture Hours	40 (8 Hours / Module)	Exam Hours	03
CREDITS – 03			
<p><b>Course Objectives:</b> This course enables students to:</p> <ul style="list-style-type: none"> <li>• Introduce the models for speech production</li> <li>• Develop time and frequency domain techniques for estimating speech parameters</li> <li>• Introduce a predictive technique for speech compression</li> <li>• Provide fundamental knowledge required to understand and analyse speech recognition, synthesis and speaker identification systems.</li> </ul>			
<b>Modules</b>			
<b>Module-1</b>			<b>RBT Level</b>
<p><b>Fundamentals of Human Speech Production:</b> The Process of Speech Production, Short-Time Fourier Representation of Speech, The Acoustic Theory of Speech Production, Lossless Tube Models of the Vocal Tract, Digital Models for Sampled Speech Signals</p>			L1, L2
<b>Module-2</b>			
<p><b>Time-Domain Methods for Speech Processing:</b> Introduction to Short-Time Analysis of Speech, Short-Time Energy and Short-Time Magnitude, Short-Time Zero-Crossing Rate, The Short-Time Autocorrelation Function, The Modified Short-Time Autocorrelation Function, The Short-Time Average Magnitude Difference Function.</p>			L1, L2
<b>Module-3</b>			
<p><b>Frequency Domain Representations:</b> Discrete-Time Fourier Analysis, Short-Time Fourier Analysis, Spectrographic Displays, Overlap Addition(OLA),Method of Synthesis, Filter Bank Summation(FBS) Method of Synthesis, Time-Decimated Filter Banks, Two-Channel Filter Banks, Implementation of the FBS Method Using the FFT, OLA Revisited, Modifications of the STFT.</p>			L1, L2
<b>Module-4</b>			
<p><b>The Cepstrum and Homomorphic Speech Processing:</b> Homomorphic Systems for Convolution, Homomorphic Analysis of the Speech Model, Computing the Short-Time Cepstrum and Complex Cepstrum of Speech, Homomorphic Filtering of Natural Speech, Cepstrum Analysis of All-Pole Models, Cepstrum Distance Measures.</p>			L1, L2, L3
<b>Module-5</b>			
<p><b>Linear Predictive Analysis of Speech Signals:</b> Basic Principles of Linear</p>			L1,L2,L3





<p>Predictive Analysis, Computation of the Gain for the Model, Frequency Domain Interpretations of Linear Predictive Analysis, Solution of the LPC Equations, The Prediction Error Signal, Some Properties of the LPC Polynomial <math>A(z)</math>, Relation of Linear Predictive Analysis to Lossless Tube Models, Alternative Representations of the LP Parameters.</p>	
<p><b>Course outcomes:</b> Upon completion of the course, students will be able to:</p> <ul style="list-style-type: none"> <li>• Model speech production system and describe the fundamentals of speech.</li> <li>• Extract and compare different speech parameters.</li> <li>• Choose an appropriate speech model for a given application.</li> <li>• Analyse speech recognition, synthesis and speaker identification systems</li> </ul>	
<p><b>Question paper pattern:</b></p> <ul style="list-style-type: none"> <li>• The question paper will have ten questions.</li> <li>• Each full question consists of 16 marks.</li> <li>• There will be 2 full questions (with a maximum of Three sub questions) from each module.</li> <li>• Each full question will have sub questions covering all the topics under a module. The students will have to answer 5 full questions, selecting one full question from each module.</li> </ul>	
<p><b>Text Book:</b></p> <ol style="list-style-type: none"> <li>1. <b>Theory and Applications of Digital Speech Processing</b>-Rabiner and Schafer, Pearson Education 2011</li> </ol>	
<p><b>Reference Books:</b></p> <ol style="list-style-type: none"> <li>1 <b>Fundamentals of Speech Recognition</b>- Lawrence Rabiner and Biing-Hwang Juang, Pearson Education, 2003.</li> <li>2 <b>Speech and Language Processing–An Introduction to Natural Language Processing, Computational Linguistics, and Speech Recognition</b>- Daniel Jurafsky and James H Martin, Pearson Prentice Hall 2009.</li> </ol>	

<b>Radar Engineering</b>			
B.E., VIII Semester, Electronics & Communication Engineering/ Telecommunication Engineering [As per Choice Based Credit System (CBCS) scheme]			
Subject Code	15EC833	IA Marks	20
Number of Lecture Hours/Week	03	Exam Marks	80
Total Number of Lecture Hours	40 (8 Hours / Module)	Exam Hours	03
<b>CREDITS – 03</b>			
<b>Course objectives:</b> This course will enable students to:			
<ul style="list-style-type: none"> <li>• Understand the Radar fundamentals and analyze the radar signals.</li> <li>• Understand various technologies involved in the design of radar transmitters and receivers.</li> <li>• Learn various radars like MTI, Doppler and tracking radars and their comparison</li> </ul>			
<b>Modules</b>			<b>RBT Level</b>
<b>Module-1</b>			
<b>Basics of Radar:</b> Introduction, Maximum Unambiguous Range, Radar Waveforms, Definitions with respect to pulse waveform - PRF, PRI, Duty Cycle, Peak Transmitter Power, Average transmitter Power. <b>Simple form of the Radar Equation,</b> Radar Block Diagram and Operation, Radar Frequencies, Applications of Radar, The Origins of Radar, Illustrative Problems. <b>(Chapter 1 of Text)</b>			L1, L2, L3
<b>Module-2</b>			
<b>The Radar Equation:</b> Prediction of Range Performance, Detection of signal in Noise, Minimum Detectable Signal, Receiver Noise, SNR, Modified Radar Range Equation, Envelope Detector — False Alarm Time and Probability, Probability of Detection, <b>Radar Cross Section of Targets:</b> simple targets – sphere, cone-sphere, Transmitter Power, PRF and Range Ambiguities, System Losses (qualitative treatment), Illustrative Problems. <b>(Chapter 2 of Text, Except 2.4, 2.6, 2.8 &amp; 2.11)</b>			L1, L2, L3
<b>Module-3</b>			
<b>MTI and Pulse Doppler Radar:</b> Introduction, Principle, Doppler Frequency Shift, Simple CW Radar, Sweep to Sweep subtraction and Delay Line Canceler, MTI Radar with – Power Amplifier Transmitter, Delay Line Cancelers — Frequency Response of Single Delay- Line Canceler, Blind Speeds, Clutter Attenuation, MTI Improvement Factor, N- Pulse Delay-Line Canceler, <b>Digital MTI Processing</b> – Blind phases, I and Q Channels, Digital MTI Doppler signal processor, Moving Target Detector- Original MTD. <b>(Chapter 3: 3.1, 3.2, 3.5, 3.6 of Text)</b>			L1, L2, L3
<b>Module-4</b>			
<b>Tracking Radar:</b> Tracking with Radar- Types of Tracking Radar Systems, Monopulse Tracking- Amplitude Comparison Monopulse (one-and two-coordinates), Phase Comparison Monopulse. <b>Sequential Lobing,</b> Conical Scan Tracking, Block Diagram of Conical Scan			L1, L2, L3

Tracking Radar, Tracking in Range, Comparison of Trackers. <b>(Chapter 4: 4.1, 4.2, 4.3 of Text)</b>	
<b>Module-5</b>	
<p><b>The Radar Antenna:</b> Functions of The Radar Antenna, Antenna Parameters, Reflector Antennas and Electronically Steered Phased array Antennas. L3 <b>(Chapter 9: 9.1, 9.2 9.4, 9.5 of Text)</b></p> <p><b>Radar Receiver:</b> The Radar Receiver, Receiver Noise Figure, Super Heterodyne Receiver, Duplexers and Receivers Protectors, Radar Displays. <b>(Chapter 11 of Text)</b></p>	L1, L2,
<p><b>Course outcomes:</b> At the end of the course, students will be able to:</p> <ul style="list-style-type: none"> <li>• Understand the radar fundamentals and radar signals.</li> <li>• Explain the working principle of pulse Doppler radars, their applications and limitations</li> <li>• Describe the working of various radar transmitters and receivers.</li> <li>• Analyze the range parameters of pulse radar system which affect the system performance</li> </ul>	
<p><b>Question paper pattern:</b></p> <ul style="list-style-type: none"> <li>• The question paper will have ten questions.</li> <li>• Each full Question consisting of 16 marks</li> <li>• There will be 2 full questions (with a maximum of Three sub questions) from each module.</li> <li>• Each full question will have sub questions covering all the topics under a module.</li> <li>• The students will have to answer 5 full questions, selecting one full question from each module.</li> </ul>	
<p><b>Text Book:</b> Introduction to Radar Systems- Merrill I Skolink, 3e, TMH, 2001.</p>	
<p><b>Reference Books:</b></p> <ol style="list-style-type: none"> <li>1. Radar Principles, Technology, Applications — Byron Edde, Pearson Education, 2004.</li> <li>2. Radar Principles – Peebles. Jr, P.Z. Wiley. New York, 1998.</li> <li>3. Principles of Modern Radar: Basic Principles – Mark A. Rkhards, James A. Scheer, William A. HoIm. Yesdee, 2013</li> </ol>	

## **MACHINE LEARNING**

### **B.E., VIII Semester, Electronics & Communication Engineering/ Telecommunication Engineering**

[As per Choice Based Credit System (CBCS) scheme]

Subject Code	15EC834	IA Marks	20
Number of Lecture Hours/Week	03	Exam Marks	80
Total Number of Lecture Hours	40 (8 Hours / Module)	Exam Hours	03
<b>CREDITS – 03</b>			
<p><b>Course Objectives:</b> This course will enable students to:</p> <ul style="list-style-type: none"> <li>• Introduce some concepts and techniques that are core to Machine Learning.</li> <li>• Understand learning and decision trees.</li> <li>• Acquire knowledge of neural networks, Bayesian techniques and instant based learning.</li> <li>• Understand analytical learning and reinforced learning.</li> </ul>			
<b>Modules</b>			
<b>Module-1</b>			<b>RBT Level</b>
<b>Learning:</b> Designing Learning systems, Perspectives and Issues, Concept Learning, Version Spaces and Candidate Elimination Algorithm, Inductive bias.			L1, L2
<b>Module-2</b>			
<b>Decision Tree and ANN:</b> Decision Tree Representation, Hypothesis Space Search, Inductive bias in decision tree, issues in Decision tree. Neural Network Representation, Perceptrons, Multilayer Networks and Back Propagation Algorithms.			L1, L2
<b>Module-3</b>			
<b>Bayesian and Computational Learning:</b> Bayes Theorem, Bayes Theorem Concept Learning, Maximum Likelihood, Minimum Description Length Principle, Bayes Optimal Classifier, Gibbs Algorithm, Naïve Bayes Classifier.			L1, L2
<b>Module-4</b>			
<b>Instant Based Learning and Learning set of rules:</b> K- Nearest Neighbour Learning, Locally Weighted Regression, Radial Basis Functions, Case-Based Reasoning. Sequential Covering Algorithms, Learning Rule Sets, Learning First Order Rules, Learning Sets of First Order Rules.			L1, L2
<b>Module-5</b>			
<b>Analytical Learning and Reinforced Learning:</b> Perfect Domain Theories, Explanation Based Learning, Inductive-Analytical Approaches, FOCL Algorithm, Reinforcement Learning.			L1, L2
<b>Course outcomes:</b> At the end of the course, students should be able to:			

- Understand the core concepts of Machine learning.
- Appreciate the underlying mathematical relationships within and across Machine Learning algorithms.
- Explain paradigms of supervised and un-supervised learning.
- Recognize a real world problem and apply the learned techniques of Machine Learning to solve the problem.

**Question paper pattern:**

- The question paper will have ten questions.
- Each full question consists of 16 marks.
- There will be 2 full questions (with a maximum of Three sub questions) from each module.
- Each full question will have sub questions covering all the topics under a module. The students will have to answer 5 full questions, selecting one full question from each module.

**Text Book:**

**Machine Learning**-Tom M. Mitchell, McGraw-Hill Education, (INDIAN EDITION), 2013.

**Reference Books:**

1. **Introduction to Machine Learning**- Ethem Alpaydin, 2nd Ed., PHI Learning Pvt. Ltd., 2013.
2. **The Elements of Statistical Learning**-T. Hastie, R. Tibshirani, J. H. Friedman, Springer; 1st edition, 2001.

## **NETWORK AND CYBER SECURITY**

### **B.E., VIII Semester, Electronics & Communication Engineering**

[As per Choice Based credit System (CBCS) Scheme]

Subject Code	15EC835	IA Marks	20
Number of Lecture Hours/Week	03	Exam marks	80
Total Number of Lecture Hours	40 (8 Hours per Module)	Exam Hours	03
CREDITS – 03			
<p><b>Course Objectives:</b> This course will enable students to:</p> <ul style="list-style-type: none"> <li>• Know about security concerns in Email and Internet Protocol.</li> <li>• Understand cyber security concepts.</li> <li>• List the problems that can arise in cyber security.</li> <li>• Discuss the various cyber security frame work.</li> </ul>			
<b>Module-1</b>			<b>RBT Level</b>
<b>Transport Level Security:</b> Web Security Considerations, Secure Sockets Layer, Transport Layer Security, HTTPS, Secure Shell (SSH) (Text 1: Chapter 15)			L1, L2
<b>Module-2</b>			
<b>E-mail Security:</b> Pretty Good Privacy, S/MIME, Domain keys identified mail (Text 1: Chapter 17)			L1, L2
<b>Module-3</b>			
<b>IP Security:</b> IP Security Overview, IP Security Policy, Encapsulation Security Payload (ESP), Combining security Associations Internet Key Exchange. Cryptographic Suites(Text 1: Chapter 18)			L1, L2
<b>Module-4</b>			
<p><b>Cyber network security concepts:</b> Security Architecture, antipattern: signature based malware detection versus polymorphic threads, document driven certification and accreditation, policy driven security certifications. Refactored solution: reputational, behavioural and entropy based malware detection.</p> <p><b>The problems:</b> cyber antipatterns concept, forces in cyber antipatterns, cyber anti pattern templates, cyber security antipattern catalog (Text-2: Chapter1 &amp; 2)</p>			L1, L2, L3
<b>Module-5</b>			
<p><b>Cyber network security concepts contd. :</b>  <b>Enterprise security using Zachman framework</b>            Zachman framework for enterprise architecture, primitive models versus composite models, architectural problem solving patterns, enterprise workshop, matrix mining, mini patterns for problem solving meetings.</p> <p><b>Case study:</b> cyber security hands on – managing administrations</p>			L1, L2, L3

<p>and root accounts, installing hardware, reimaging OS, installing system protection/ antimalware, configuring firewalls (Text-2: Chapter 3 &amp; 4).</p>	
<p><b>Course Outcomes:</b> After studying this course, students will be able to:</p> <ul style="list-style-type: none"> <li>• Explain network security protocols</li> <li>• Understand the basic concepts of cyber security</li> <li>• Discuss the cyber security problems</li> <li>• Explain Enterprise Security Framework</li> <li>• Apply concept of cyber security framework in computer system administration</li> </ul>	
<p><b>Question paper pattern:</b></p> <ul style="list-style-type: none"> <li>• The question paper will have 10 full questions carrying equal marks.</li> <li>• Each full question consists of 16 marks with a maximum of Three sub questions.</li> <li>• There will be 2 full questions from each module covering all the topics of the module</li> <li>• The students will have to answer 5 full questions, selecting one full question from each module.</li> </ul>	
<p><b>Text Books:</b></p> <ol style="list-style-type: none"> <li>1. William Stallings, “Cryptography and Network Security Principles and Practice”, Pearson Education Inc., 6<sup>th</sup> Edition, 2014, ISBN: 978-93-325-1877-3.</li> <li>2. Thomas J. Mowbray, “Cyber Security – Managing Systems, Conducting Testing, and Investigating Intrusions”, Wiley.</li> </ol>	
<p><b>Reference Books:</b></p> <ol style="list-style-type: none"> <li>1. Cryptography and Network Security, Behrouz A. Forouzan, TMH, 2007.</li> <li>2. Cryptography and Network Security, Atul Kahate, TMH, 2003.</li> </ol>	